



ELITE FORCE







RACE-GUN

CO₂ AIRSOFT / cal. 6 mm BB

- EN** Operating instructions 3 - 13 **DE** Bedienungsanleitung 13 - 24
FR Mode d'emploi 25 - 35 **ES** Manual de instrucciones 36 - 46

2.5799 | 2.6337-1 | 11/15 © 2015

INTRODUCTION | EINLEITUNG | INTRODUCTION | INTRODUCCIÓN

				
EN	Description	Operation	Maintenance	Safety instructions
DE	Benennung	Bedienung	Pflege	Sicherheitshinweise
FR	Désignation des pièces	Emploi	Entretien	Consignes de sécurité
ES	Designacion	Reglaje	Cuidados	Instrucciones de seguridad

FR

Cette boîte contient: une réplique d'arme factice avec chargeur. Les AIR SOFT GUNS sont des modèles d'armes factices tirant des billes en plastique de 6 mm inoffensives. Ce modèle a une énergie comprise entre 0,08 joule et inférieure ou égale à 2 joules.

En France, la vente de ces produits est réglementée par le décret n°99-240 du 24 mars 1999, qui interdit la distribution des modèles noirs ou chromés dont l'énergie est comprise entre 0,08 et 2 joules aux moins de 18 ans non accompagnées.

Ce décret ne concerne pas les modèles transparents, les game guns (oranges) et les mini guns, dont la distribution reste donc autorisée aux mineurs.

- Distribution et vente interdite aux mineurs.
- Attention: Ne jamais diriger le tir vers une personne.



SAFE GUN HANDLING

EN

You should be fully familiar with the proper and safe handling of your gun. The basic principles of gun safety require you to always apply the following rules when handling the firearm.

- Always treat a gun as if it was loaded.
- Always put the safety of a gun to "safe" when loading it so that there can be no unintentional discharge.
- Keep your finger away from the trigger. It should be straight and should rest on the trigger guard.
- Only use the kind of projectiles suitable for your gun.
- Always keep the muzzle pointed in a safe direction.
- This gun may only be discharged in your own house, on authorized shooting ranges and inside enclosed private property. It is to be made sure that no projectile can leave the enclosed property.
- Keep the danger area of the projectile in mind.
- Never transport a loaded gun. Only load your gun when you intend to fire it.
- Never aim your airgun at persons or animals. Avoid ricochets. Never fire at smooth, hard surfaces or water.
- Before you discharge your gun, make sure that target and surrounding area are safe.
- Always make sure that the gun is not loaded when you transport it or take it from another person.
- Make sure that you always have full control over the muzzle of your gun, even if you stumble or fall down.
- Safety shooting glasses should always be worn when firing the gun.
- Always store your gun in a safe place and in unloaded condition. Unauthorized persons (persons not familiar with the use of guns, children) must not have access to it. Ammunition is to be kept in a separate place.
- This gun and its instruction manual may only be passed on to persons
 - who are fully familiar with its use and
 - who have reached the legally stipulated minimum age in the respective country.
- Modifications or repairs of guns are only to be effected by authorized agencies or by a skilled gunsmith.
- Never leave a loaded gun unattended.
- Only unloaded guns are to be handed over to another person.

REPAIR

A gun that does not work properly is dangerous. Do not attempt to repair this pistol if it needs service. Incorrect assembly could lead to dangerous malfunctions.

Caution: Repairs should only be completed by UMAREX authorized centres.



SAFETY INSTRUCTIONS | WARRANTY

EN



CAUTION

For your own safety and the safety of others, carefully read these instructions before using this gun. Buyers and owners must observe all rules concerning the use and ownership of air guns. Modifying this gun may result in a change of its classification under guns law and is therefore prohibited. In such cases the manufacturer's warranty will immediately become void.



WARNING

Do not brandish or display this airgun in public - it may confuse people and may be a crime. Police and others may think this airgun is a firearm. Do not change the coloration and markings to make it look more like a firearm. That is dangerous and may be a crime.

WARRANTY

During the legal warranty period, which begins on the date of purchase, UMAREX will repair or replace your gun at no charge provided the defect was not caused by you. Return your gun to an authorized dealer along with a description of the problem and proof of purchase.

The air guns manufactured by UMAREX GmbH & Co. KG are made according to the regulations of the PTB (Physikalisch-Technische Bundesanstalt), German federal law, the CIP regulations and the technical know-how of UMAREX GmbH & Co. KG.

We will not assume any liability whatsoever if this product is exported to territories outside of Germany and as a consequence does not comply with domestic legal requirements of these territories. It will be the sole responsibility of the importer to ensure compliance with local laws and regulations.

TECHNICAL DATA

Item no.	2.5799	2.6337-1
System	CO ₂ Airsoft	
Power source	12 g CO ₂ capsule	
Caliber / Ammo	6 mm BBs	
Capacity	16 rounds (BBs)	
Energy	2 Joules max.	
Velocity	up to 120 m/s	
Drive	Semi-Auto	
Color	black	
Safety	manual	
Barrel length	160 mm	
Dangerous area up to	250 m	
Weight	1100 g	
Length	265 mm	



DESCRIPTION

EN

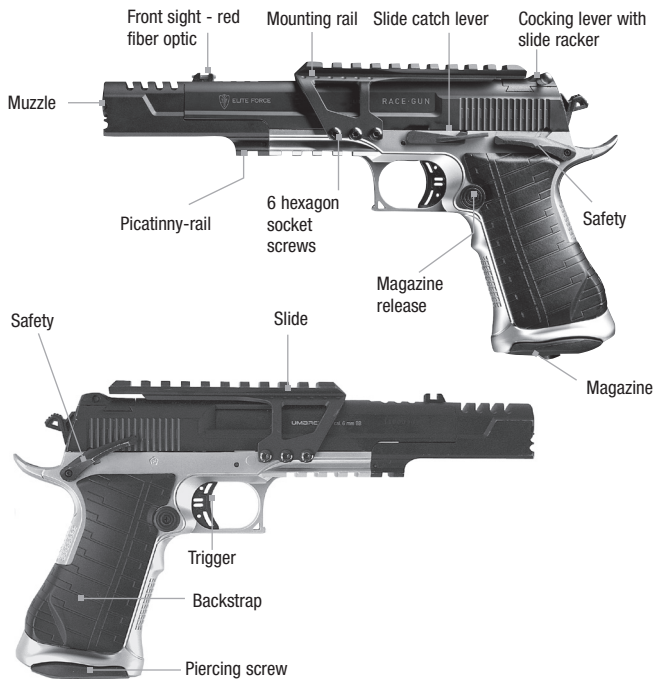

INTERCHANGEABLE REAR SIGHTS

(pre-mounted):

Fiber optic sight



Standard rear sight



COCKING LEVER:

Cocking lever

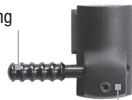

Slide racker,
pre-mounted



SAFETY

EN



CAUTION

- Only handle your gun in its safe condition.
- Always make sure that the muzzle points in a safe direction.

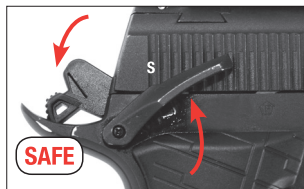
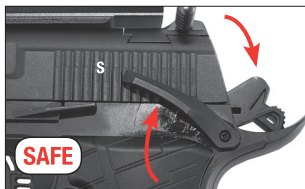

PROBLEM SOLUTIONS



PROBLEMS

Faulty shooting direction

Weapon does not shoot

Low shooting speed

POSSIBLE CAUSES

	Safety activated	CO ₂ capsule not inserted	Gas / CO ₂ capsule / Magazine empty	Dirty barrel	Extreme temperatures	Wrong ammunition	Ammunition badly loaded	Sight not properly adjusted	
Faulty shooting direction			●	●	●	●	●	●	
Weapon does not shoot	●	●	●		●	●	●		
Low shooting speed			●	●	●	●	●		



INSERTING AND CHANGE CO₂-CAPSULE

EN



CAUTION

- Only use 12 g CO₂ capsules.
 - For storage remove gas capsules.
 - There may be a minor discharge of gas when you remove the gas capsules.
- Make sure that your hands do not come into contact with discharged CO₂ gas. This may cause freezing of the skin. Do not expose the CO₂ cartridge to excessive heat and do not store it at temperatures exceeding 54°C. Always adhere to the warnings and safety instructions of the manufacturer on the gas cartridge in respect to handling and storage of a CO₂ gas container.



1. Press magazine holder.
2. Remove the magazine.

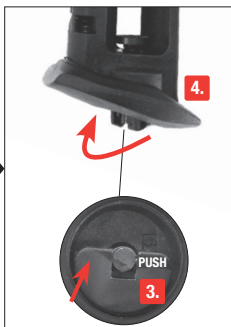

3. Push the screw to flip back the screw cap. 4. Turn capsule piercing screw downwards.

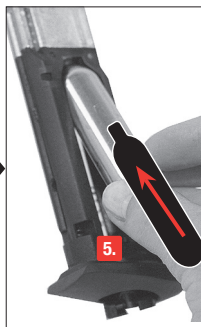

5. Insert CO₂ capsule as shown.



6. Turn the piercing screw upwards, pierce CO₂ capsule.



7. Insert magazine



LOADING THE MAGAZINE

EN

CAUTION



Only use flawless BBs: Never use the following BBs:

1 diameter larger than 6mm, **2** with edges, **3** both halves not aligned, **4** used, soiled. Warranty expires if non-recommended BBs are used. It's recommended to use precision BBs from UMAREX/Walther. To ensure proper operation of the magazine, protect it from dirt and dust.



1. Press magazine. **2.** Remove the magazine.

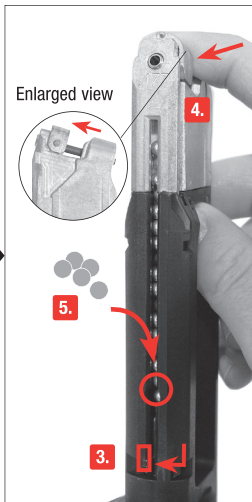

3. Pull down and lock magazine follower. **4.** When loading, move the follower as shown in the enlarged view and hold it in place. **5.** Load BBs. Unlock follower.



6. Hold the magazine in a horizontal position to let BBs into the follower. **7.** Insert magazine.



INTERCHANGEABLE REAR SIGHTS

EN

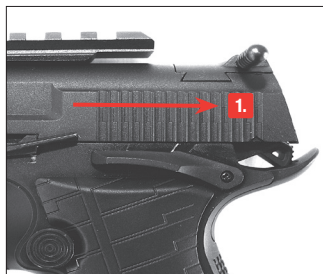

1. Pull the slide to the end.



2. Using a 1.5 mm Allen key, **3.** remove the slide racker from its guide.

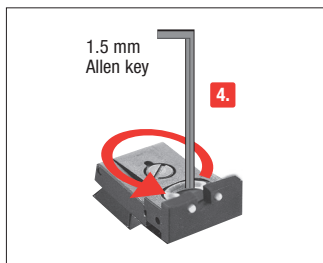

4. Slightly loosen the headless screw and place the sight in the dovetail guide.

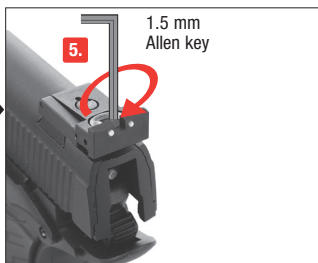

5. Tighten the screw. Push down the slide catch lever (release the slide).



REPLACING THE REAR SIGHT

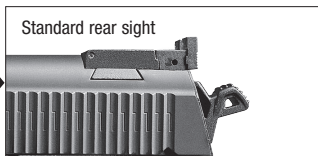
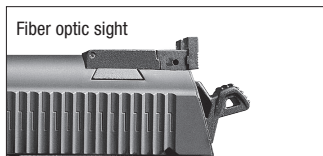

To replace the rear sight reverse the steps described in "Interchangeable rear sights".



MOUNTING OF ACCESSORIES

EN

SLIDE RACKER



1. Pull the slide to the end.



2. Remove the rear sight as described in "Interchangeable rear sights".

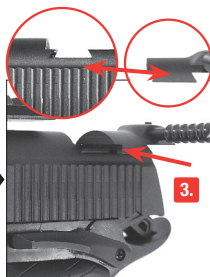

3. Place the slide racker in the dovetail guide.

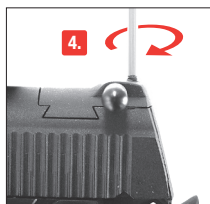

4. Using a 1.5 mm Allen key, to fix the slide racker.



5. The cocking lever is ambidextrous.



6. Push down the slide catch lever (release the slide).

MOUNTING RAIL

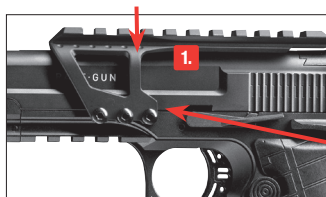

1. Attach the mounting rail.

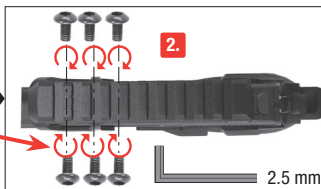

2. Tighten 6 screws.



SIGHTS

EN

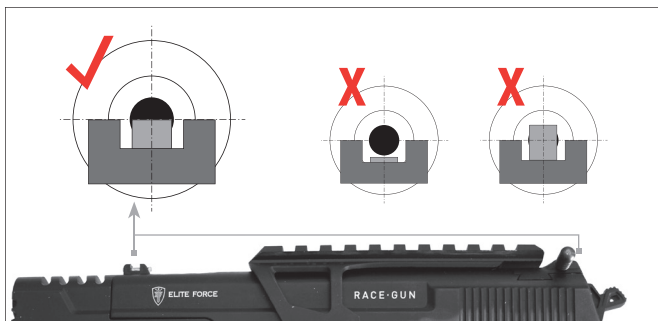

ADJUSTABLE REAR SIGHT

Elevation adjustment

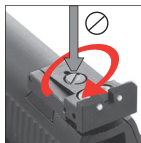

Shots are too high



turn to the right

Shots are too low



turn to the left

Windage adjustment

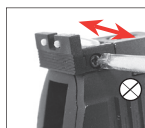

Shots are left of center



turn to the right

Shots are right of center



turn to the left





SHOOTING

EN



1. Put safety on "fire".



2. To cock the pistol pull the slide to the end and push the slide back to front position.



3. Pull trigger.



BARREL CLEANING

EN



CAUTION

- Unload the gun before cleaning the gun.
- Do not force the rod into the barrel, as this could cause damage.
- Occasionally clean the metal parts on the outside. Use a cloth which has been slightly dampened with some gun oil.
- Never drip silicone oil directly into the barrel.

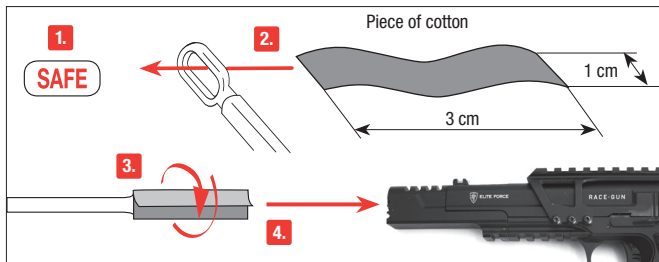

Put the safety on "safe". Prepare a thin rod with a length of approx. 30 cm. Attach a piece of cotton fabric to its end and clean the barrel with some silicone oil.

MAINTENANCE (FOR CO₂ GUN ONLY)

Clean your gun at regular intervals (250 shots) using a maintenance capsule. We recommend the use of the WALTHER maintenance capsule 4.1683.

How to use the maintenance capsule:

Remove all BBs from the gun, insert the maintenance capsule and pierce it. Turn the gun upside-down so that the trigger is on top. Then point the gun in a safe direction and fire until the capsule is empty.







SICHERER UMGANG MIT WAFFEN

DE

Sie sollten mit der richtigen, sicheren Handhabung Ihrer Waffe vertraut sein. Im Hinblick auf die Grundregeln zum sicheren Schießen bedenken Sie, dass jede Berührung mit der Waffe als Handhabung verstanden wird.

- Behandeln Sie jede Waffe so, als wäre sie geladen.
- Die Waffe beim Laden stets sichern, so dass sich kein Schuss ungewollt lösen kann.
- Finger immer außerhalb des Abzugsbügels halten und nur zum Schuss an den Abzug legen.
- Verwenden Sie nur für diese Waffe vorgesehene Geschosse.
- Halten Sie die Mündung stets in eine sichere Richtung.
- Das Schießen ist nur in der eigenen Wohnung, auf polizeilich zugelassenen Schießständen und im befriedeten Besitztum erlaubt, wenn das Geschoss dieses beim Schuss nicht verlassen kann. Hierbei den Gefahrenbereich des Geschosses beachten.
- Transportieren Sie niemals eine geladene Waffe. Laden Sie nur, wenn Sie schießen möchten.
- Waffe niemals auf Menschen oder Tiere richten. Vermeiden Sie Querschläger. Schießen Sie niemals auf glatte, harte Oberflächen oder auf Wasserflächen.
- Vergewissern Sie sich vor dem Schuss, dass Ziel und Umgebungsbereich sicher sind.
- Kontrollieren Sie immer, ob die Waffe ungeladen ist, wenn Sie sie transportieren oder von einer anderen Person übernehmen.
- Vergewissern Sie sich, dass Sie auch beim Stolpern oder Stürzen die Richtung der Mündung kontrollieren können.
- Aus Sicherheitsgründen sollte beim Schießen eine Schutzbrille getragen werden.
- Aufbewahren der Waffe stets sicher und ungeladen vor unerlaubtem Zugriff Unbefugter (ungeschulte Personen, Kinder, Personen unter 18 Jahren) und getrennt von der Munition.
- Weitergabe dieser Waffe mit der Bedienungsanleitung nur an Personen
 - die mit dieser Waffe genauestens vertraut und
 - bei Waffen mit -Zeichen mindestens 18 Jahre alt sind.
- Druckluftwaffen mit Energie > 0,5 Joule aber ohne -Zeichen sind erwerbscheinpflchtig
- Elektrische und Federdruckwaffen < 0,5 Joule sind frei ab 14 Jahren.
- Elektrische und Federdruckwaffen < 0,08 Joule sind frei ab 3 Jahren.
- Jegliche Veränderungen oder Reparaturen von Waffen sollten nur von fachkundigen Firmen oder vom Büchsenmacher durchgeführt werden.
- Legen Sie niemals eine geladene Waffe aus der Hand.
- Geben Sie nur entladene Waffen an andere Personen weiter.

REPARATUR

Eine Waffe, die nicht einwandfrei funktioniert, ist gefährlich. Es ist schwierig, eine Waffe selbst zu reparieren, und falscher Zusammenbau kann zu gefährlichen Funktionsstörungen führen.

**Achtung: Lassen Sie die Waffe nur von einem autorisiertem Fachhändler/
Büchsenmacher überprüfen und reparieren.**



SICHERHEITSHINWEISE | GARANTIE

DE



ACHTUNG

Zu Ihrer eigenen und zur Sicherheit anderer lesen Sie die Bedienungsanleitung vollständig und sorgfältig durch, bevor Sie mit der Waffe erstmalig hantieren. Käufer und Besitzer haben die Pflicht, alle Regeln über den Gebrauch und den Besitz von Druckluftwaffen zu befolgen. Jede Änderung an dieser Waffe kann zu einer Änderung der waffenrechtlichen Einstufung führen und ist somit unzulässig. Die Gewährleistung des Herstellers erlischt in diesem Fall sofort.



WARNUNG

Diese Druckluftwaffe nicht in der Öffentlichkeit zeigen oder mit ihr drohen - es führt zu Verwechslungen mit echten Waffen und gilt als Straftat. Ändern Sie keinesfalls die Farbe und Markierungen der Druckluftwaffe, um ihr Aussehen mehr einer realen Schusswaffe anzugleichen. Dies ist gefährlich und gilt als Straftat.

GARANTIE

Innerhalb des gesetzlich festgelegten Zeitraumes ab Kaufdatum repariert oder ersetzt Ihnen die Fa. UMAREX Ihre Waffe kostenlos, falls der Defekt nicht durch Eigenverschulden aufgetreten ist. Geben Sie die Waffe einem autorisierten Händler, beschreiben Sie ihm das Problem und fügen Sie den entsprechenden Kaufbeleg bei.

Die von UMAREX GmbH & Co. KG hergestellten Druckluftwaffen werden gemäß den Zulassungsvorschriften der Physikalisch-Technischer Bundesanstalt (PTB), dem Bundesgesetz, den CIP-Vorschriften und dem waffen-technischen Know-how der Firma UMAREX GmbH & Co. KG hergestellt.

Somit übernehmen wir keine Haftung, falls diese Ware nach dem Export ins Ausland nicht den dort geltenden Rechtsvorschriften entsprechen sollte und dem Besitzer/Käufer juristische Schwierigkeiten und Konsequenzen daraus entstehen sollten.

TECHNISCHE DATEN

Art.Nr.	2.5799	2.6337-1
System	CO ₂ Airsoft	
Energiequelle	12 g CO ₂ capsule	
Kaliber / Munition	6 mm BBs	
Kapazität	16 Schuss (BBs)	
Energie	2 Joules max.	
Geschwindigkeit	bis zu 120 m/s	
Funktion	Semi-Auto	
Farbe	Schwarz	
Sicherung	manuell	
Lauflänge	160 mm	
Max. Gefahrenbereich bis zu	250 m	
Gewicht	1100 g	
Gesamtlänge	265 mm	



BENENNUNG

DE

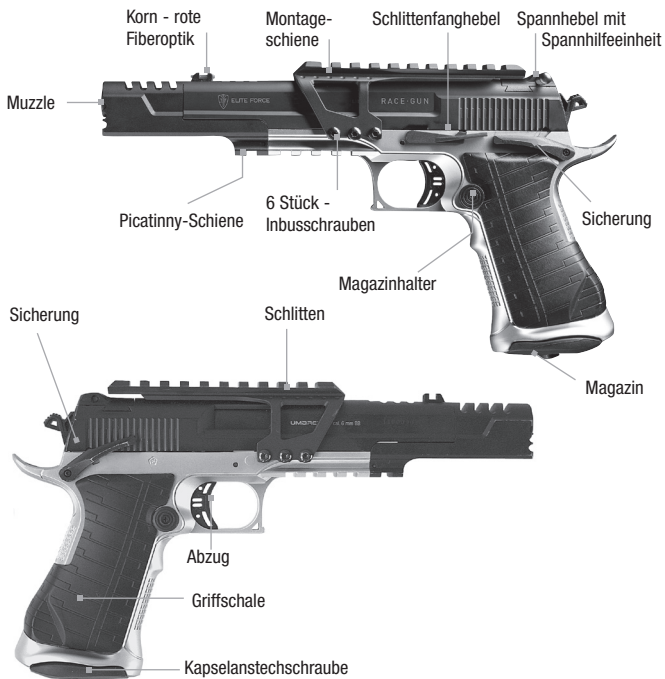

WECHSELKIMMEN (vormontiert) :

Fiberoptik



Standard-Kimme



SPANNHEBEL:

Spannhebel

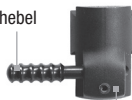

Spannhilfeeinheit vormontiert



SICHERUNG

DE



ACHTUNG

- Hantieren Sie nur mit der Waffe, wenn diese gesichert ist.
- Achten Sie stets darauf, dass die Mündung in eine sichere Richtung zeigt.

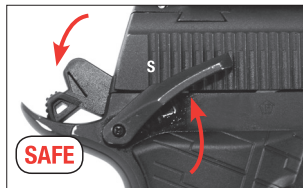
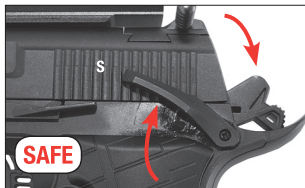

PROBLEMLÖSUNGEN



PROBLEME

schlechte Schussleistung
Waffe schießt nicht
geringe Geschwindigkeit

MÖGLICHE GRÜNDE

Waffe gesichert	CO ₂ -Kapsel nicht angestoßen	Gas / CO ₂ -Kapsel / Magazin leer	Lauf verschmutzt	Extreme Temperaturen	Falsche Munition	Munition falsch geladen	Visierung nicht richtig eingestellt
		●	●	●	●	●	●
●	●	●		●	●	●	
		●	●	●	●	●	



INSETZEN UND AUSTAUSCHEN DER CO₂-KAPSEL

DE

ACHTUNG

- Verwenden Sie nur 12 g CO₂-Kapseln.
- Für die Lagerung der Waffe CO₂-Kapsel entnehmen!
- Beim Herausnehmen der CO₂-Kapsel kann es zu einem leichten Austritt von CO₂ kommen. Achten Sie darauf, dass Ihre Hände nicht mit austretendem CO₂-Gas in Berührung kommen. Bei Kontakt mit der Hand kann es zu Erfrierungen kommen. Setzen Sie die CO₂-Kapsel keiner großen Hitze aus und lagern Sie diese Behälter nicht bei Temperaturen über 54°C. Halten Sie sich immer an die auf der CO₂-Kapsel ausgedruckten Warn- und Sicherheitshinweise des Herstellers bezüglich Umgang und Lagerung der CO₂-Kapsel.



1. Magazinehalter drücken.
2. Magazin entnehmen.



3. Drücken Sie auf die Schraube, damit der Schraubverschluss umklappt.
4. Kapselansteckschraube nach unten drehen.

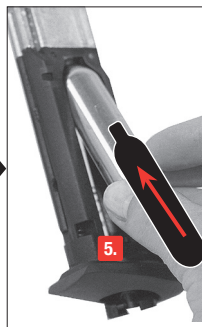

5. CO₂-Kapsel wie abgebildet einlegen.



6. Kapselansteckschraube hochdrehen, Kapsel anstecken.



7. Magazin einsetzen.



MAGAZIN LADEN

DE



ACHTUNG



Verwenden Sie nur einwandfreie BB-Kugeln: \varnothing 6 mm. Verwenden Sie auf keinen Fall folgende BB-Kugeln:

1 Durchmesser größer als 6 mm, 2 mit Grat, 3 versetzte Hälften, 4 gebraucht, verschmutzt. Bei Gebrauch ungeeigneter Geschosse erlischt die Garantie. Empfohlen werden Präzisionsrundkugeln des Herstellers UMAREX/WALTHER. Vermeiden Sie das Eindringen von Schmutz und Staub in das Magazin.



1. Magazinhalter drücken.
2. Magazin entnehmen.

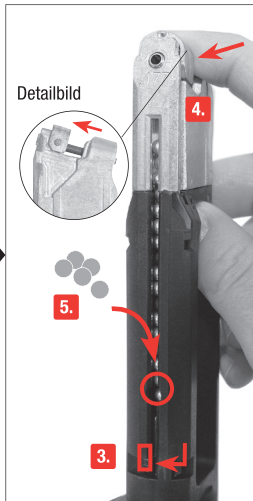

3. Zuführer runterziehen und einrasten. 4. Geschossezubringer während des Ladens entsprechend Detailbild schieben und festhalten.
5. BBs laden. Zuführer entrasten.



6. Halten Sie das Magazin waagrecht, damit die Kugeln in den Zubringer gelangen.
7. Magazin einsetzen.



WECHSELKIMMEN

DE

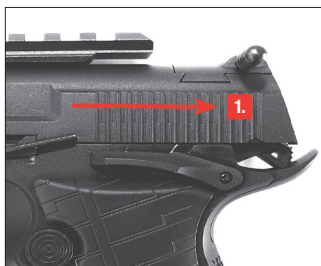

1. Ziehen Sie den Schlitten zurück.

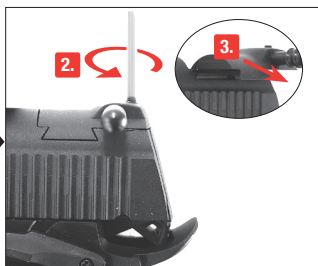

2. Mit einem 1,5 mm Inbusschlüssel die Spannhilfeeinheit lösen. **3.** Schlitten nach hinten ziehen und die Spannhilfeeinheit aus der Führung entnehmen.

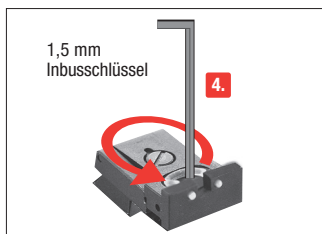

4. Schrauben Sie die Madenschraube mit einem 1,5 mm Inbusschlüssel etwas heraus, um die Kimme in die Schwabenschwanzführung zu setzen.

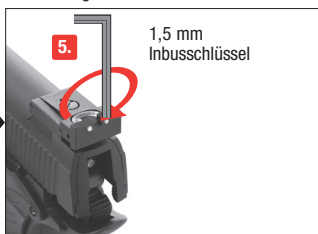

5. Schrauben Sie die Schraube fest. Schlittenfanghebel nach unten drücken (Schlitten entspannen).



UMBAU DER KIMME

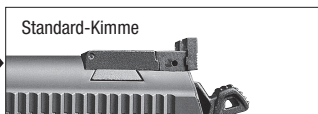
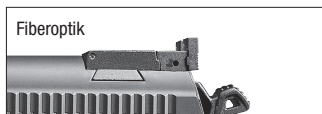

Gehen Sie zum Umbau der Kimme in der gleichen Reihenfolge vor, wie unter "Wechselkimmen" beschrieben.



MONTAGE DES ZUBEHÖRS

DE

SPANNHILFE



1. Ziehen Sie den Schlitten zurück.



2. Entnehmen Sie die Kimme wie unter "WECHSELKIMMEN" beschrieben.

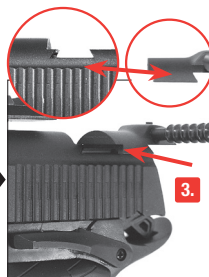

3. Setzen Sie die Spannhilfe-einheit in die Schwalbenschwanzführung ein.

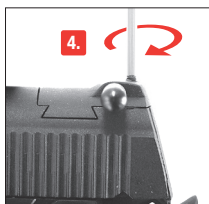

4. Mit einem 1,5 mm Inbusschlüssel die Spannhilfe-einheit fixieren.



5. Der Spannhebel ist beidseitig montierbar.



6. Schlittenfanghebel nach unten drücken (Schlitten entspannen).

MONTAGESCHIENE

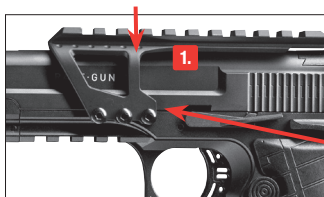

1. Montageschiene aufsetzen.

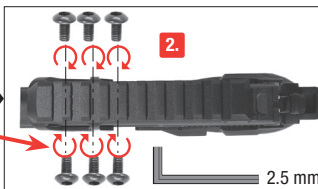

2. 6 Schrauben befestigen.



VISIERUNG EINSTELLEN

DE

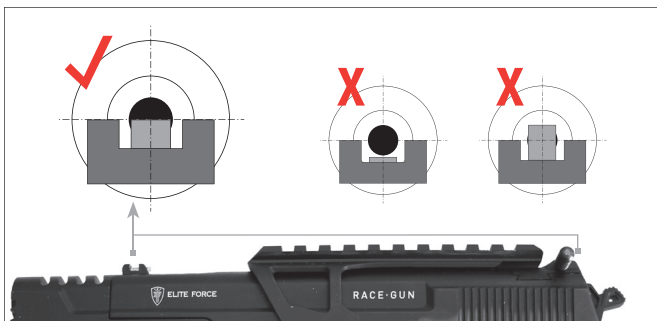

EINSTELLEN DER KIMME

Höhenverstellung

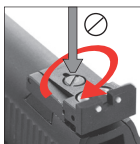

Schuss zu hoch   nach rechts drehen

Schuss zu tief   nach links drehen

Seitenverstellung



Schuss zu weit links   nach rechts drehen

Schuss zu weit rechts   nach links drehen





SCHIESSEN

DE



1. Entsichern.



2. Um die Pistole zu spannen, ziehen Sie den Schlitten zurück und bringen ihn wieder nach vorn.



3. Abzug betätigen.



ACHTUNG

- Entladen Sie die Waffe bevor Sie die Waffe reinigen.
- Schieben Sie den Stab niemals mit Gewalt in den Lauf, dies kann Beschädigungen verursachen.
- Reinigen Sie gelegentlich die äußeren Metallteile. Benutzen Sie dazu ein Tuch, auf das Sie leicht Waffenöl aufgetragen haben.
- Geben Sie niemals das Waffenöl direkt in den Lauf.

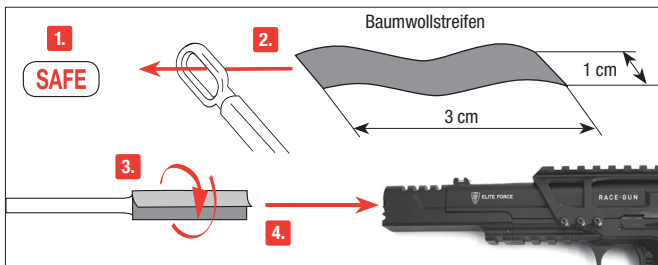

Sichern Sie die Waffe. Nehmen Sie einen ca. 30 cm dünnen, langen Stab. Wickeln Sie ein Stück Baumwolltuch um das Ende, benetzen Sie das Tuch mit etwas Waffen-Öl und reinigen Sie damit den Lauf.

PFLEGE (NUR FÜR CO₂-WAFFEN)

Pflegen Sie die Waffe in regelmäßigen Abständen (ca. 250 Schuss) mithilfe einer Wartungskapsel. Wir empfehlen die Verwendung der WALTHER Wartungskapseln 4.1683.

Anwendung der Wartungskapsel:

BBs aus der Waffe entnehmen, Wartungskapsel einlegen und anstecken.
Waffe auf den Kopf drehen und die Wartungskapsel leer schießen.





MANIEMENT DES ARMES EN TOUTE SÉCURITÉ

FR

Vous devez savoir manier votre arme correctement et de manière sûre et devez impérativement respecter les règles de base de tir en toute sécurité à chaque fois que vous manipulez l'arme.

- Maniez toujours l'arme comme si elle était chargée.
- Mettez toujours la sécurité avant de charger l'arme afin d'éviter tout tir involontaire.
- Ne mettez pas le doigt sur la détente et ne l'y placez que lorsque vous allez tirer.
- N'utilisez que les projectiles prévus pour cette arme.
- Pointez toujours la bouche de l'arme dans une direction non dangereuse.
- Il n'est permis de tirer avec l'arme que sur le lieu de résidence du propriétaire ou dans des zones de tir autorisées par la police, à condition que le projectile ne puisse pas sortir de la zone de tir. Veuillez toujours prendre en compte la zone de danger maximale du projectile.
- Ne transportez jamais l'arme lorsqu'elle est chargée. Ne la chargez que lorsque vous apprêtez à tirer.
- Ne dirigez jamais l'arme vers des personnes ni des animaux. Evitez les tirs pouvant faire ricocher le projectile. Ne tirez jamais sur des surfaces planes et dures, ni sur une surface d'eau car les projectiles peuvent ricocher.
- Avant de tirer, assurez-vous que l'objectif et les alentours ne présentent pas de danger.
- Vérifiez toujours que l'arme est déchargée avant de la transporter ou de la remettre à autrui.
- Veillez à maîtriser la direction dans laquelle la bouche de l'arme est pointée, même si vous trébuchez ou tombez.
- Pour des raisons de sécurité, portez des lunettes de protection lorsque vous tirez.
- Rangez toujours l'arme déchargée, séparée des munitions et dans un endroit sûr afin d'éviter que des personnes non autorisées (personnes non formées, enfants) puissent y avoir accès.
- Ne remettez cette arme, accompagnée du mode d'emploi, qu'à des personnes
 - qui sont le plus possible formées au maniement de cette arme et
 - qui ont atteint l'âge minimum légal selon la loi sur les armes en vigueur dans votre pays.
- Toute modification ou réparation de l'arme devra être effectuée par une entreprise spécialisée ou un armurier.
- Ne laissez jamais l'arme chargée sans surveillance.
- Déchargez toujours l'arme avant de la remettre à autrui.

RÉPARATION

Une arme qui ne fonctionne pas parfaitement est dangereuse. Il est difficile de réparer une arme soi-même, et un remontage incorrect peut entraîner des dysfonctionnements dangereux.

Attention : Seules des personnes spécialisées agréées ou un armurier peuvent contrôler et réparer l'arme.



CONSIGNES DE SÉCURITÉ | GARANTIE

FR



ATTENTION

Pour votre sécurité et celle d'autrui, lisez attentivement le mode d'emploi avant d'utiliser l'arme pour la première fois. Les vendeurs, tout comme les acheteurs, ont l'obligation de respecter le règlement relatif à l'utilisation et à la possession d'armes à air comprimé. Il est interdit de procéder à toute modification de ce pistolet car cela pourrait entraîner un changement dans la classification correspondant à la législation sur les armes à feu. De plus, toute modification entraînerait l'annulation immédiate de la garantie du fabricant.



MISE EN GARDE

N'exhibez pas cette arme à air comprimé et ne la sortez pas en public. Cela pourrait prêter à confusion ou être considéré comme un délit. Les membres des forces de sécurité et la police pourraient la prendre pour une vraie arme à feu. Ne changez pas sa couleur ni les éléments d'identification pour qu'elle ressemble plus à une vraie arme à feu. Cela serait dangereux et peut être considéré comme un délit.

GARANTIE

La société UMAREX s'engage à réparer ou à remplacer votre arme durant une période déterminée légalement à compter de la date d'achat, à condition que vous ne soyez pas responsable du défaut. Pour cela, remettez l'arme à un revendeur autorisé, décrivez-lui le problème et joignez le justificatif d'achat correspondant.

Les armes à air comprimé de la société UMAREX GmbH & Co. KG sont fabriquées conformément aux directives de conformité de l'institut allemand « Physikalisch-Technische Bundesanstalt (PTB) », à la loi fédérale, aux prescriptions CIP et au savoir-faire technique de la société UMAREX GmbH & Co. KG dans le domaine des armes.

Ainsi, nous ne pouvons être tenus responsables si, après exportation à l'étranger, cette marchandise ne répond pas aux prescriptions légales en vigueur dans le pays en question et si le possesseur/acheteur doit pour cette raison faire face à des difficultés juridiques ou toute autre conséquence pouvant découler de ce fait.

DONNÉES TECHNIQUES

Numéro d'article	2.5799	2.6337-1
Système	CO ₂ Airsoft	
Source de propulsion	12 g CO ₂ capsule	
Calibre / Munitions	6 mm BBs	
Capacité	16 Coups (BBs)	
Énergie	2 J max.	
Vitesse	jusqu'à 120 m/s	
Action	Semi-Auto	
Couleur	noir	
Sécurité	manuel	
Longueur canon	160 mm	
Zone de danger s'étendant	250 m	
Poids	1100 g	
Longueur	265 mm	



DÉSIGNATION DES PIÈCES

FR



CRANS DE MIRE DE RECHANGE (prémontés) :

Fibre optique



Cran de mire standard



LEVIER D'ARMEMENT:

Levier d'armement

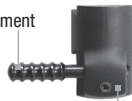

Unité auxiliaire d'armement
(prémontée)



SÉCURITÉ

FR



ATTENTION

- Ne manipulez l'arme que lorsque la sécurité est enclenchée.
- Assurez-vous que la bouche est orientée dans une direction non dangereuse.

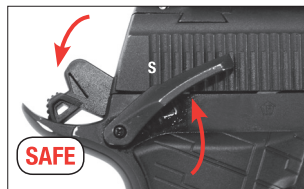
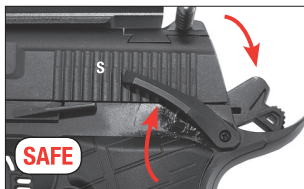

DYSFONCTIONNEMENTS



DYSFONCTIONNEMENTS

mauvaise performance de tir

l'arme ne tire pas

faible vitesse du projectile

CAUSES POSSIBLES

	sûreté de l'arme enclenchée	Cartouche de CO2 non percée	Gaz / cartouche de CO ₂ vide / Chargeur vide	canon encrassé	températures extrêmes	mauvaises munitions	munitions mal chargées	dispositif de visée mal réglé
mauvaise performance de tir			●	●	●	●	●	●
l'arme ne tire pas	●	●	●		●	●	●	
faible vitesse du projectile			●	●	●	●	●	



INSERTION DE LA CAPSULE DE CO₂

FR

ATTENTION

- Utilisez seulement des capsules de CO₂ de 12 g.
- Retirez la capsule de CO₂ avant de ranger l'arme.
- En retirant la capsule de CO₂, il est possible qu'une petite quantité de gaz s'échappe. Veillez à ce que vos mains n'entrent pas en contact avec le gaz CO₂ qui s'échappe. Le contact avec la peau peut entraîner des gelures. Ne soumettez pas les capsules de CO₂ à une chaleur trop importante et ne les stockez pas à des températures supérieures à 54 °C. Respectez toujours les consignes de sécurité et avertissements figurant sur la capsule de CO₂ relatifs à l'utilisation et au stockage de capsules de CO₂.



1. Appuyez sur l'arrêt du chargeur. 2. Retirez le chargeur.



3. Appuyez sur la vis afin que la fermeture vissée s'ouvre. 4. Tournez la vis perforante vers le bas.

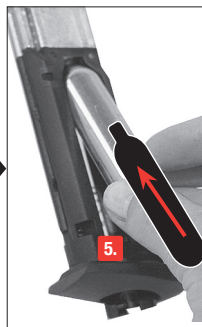

5. Insérez la cartouche de CO₂ comme indiqué.



6. Revissez la vis perforante pour percer la cartouche de CO₂.



7. Poussez le chargeur.



CHARGEMENT DES BILLES BB

FR

ATTENTION



N'utilisez que des billes BB (sans défaut). N'utilisez jamais les types de billes BB suivants:

1 Diamètre supérieur à 6 mm **2** avec angles **3** moitiés déplacées **4** usagées, sales. Si des projectiles autres que ceux appropriés sont utilisés, la garantie ne sera plus valable. Il est recommandé d'utiliser des billes de précision de la marque UMAREX/Walther. Pour garantir le bon fonctionnement du chargeur, faites en sorte que les saletés et poussières n'entrent pas dans le chargeur.



1. Appuyez sur l'arrêtoir du chargeur. **2.** Retirez le chargeur.

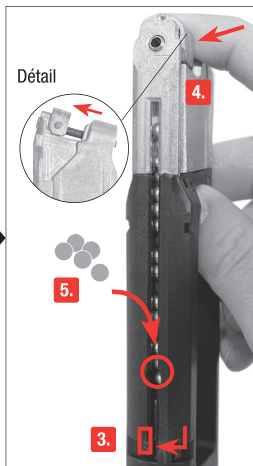

3. Poussez la retenue du chargeur vers le bas et enclenchez-la. **4.** Poussez et maintenez le dispositif d'alimentation comme indiqué sur la figure pendant le chargement. **5.** Introduisez les billes BB. Débloquez la retenue du ressort.



6. Tenez le chargeur à l'horizontale pour que les munitions se retrouvent dans le dispositif d'alimentation. **7.** Poussez le chargeur.



CRANS DE MIRE DE RECHANGE

FR

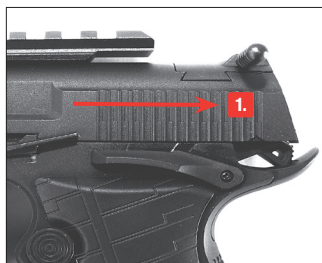

1. Tirez la culasse vers l'arrière.

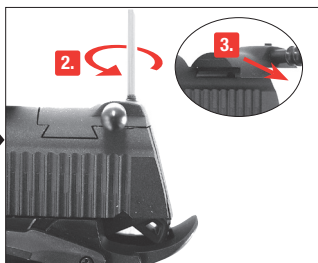

2. Avec une clé mâle à six pans de 1,5 mm dévissez l'unité auxiliaire d'armement **3.**
Tirez la culasse vers l'arrière, et retirez-la du guidage.

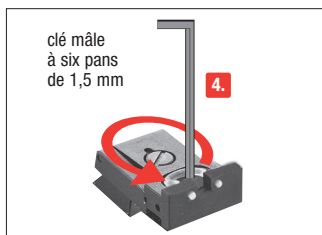

4. Dévissez légèrement la vis sans tête pour placer le cran de mire dans le guidage en queue d'hirondelle.

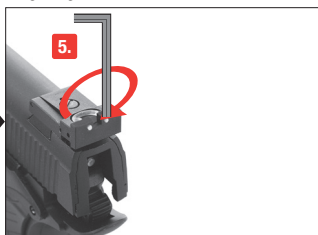

5. Vissez fermement la vis.
Poussez l'arrêt de culasse vers le bas (désarmement de la culasse).



REPLACEMENT DU CRAN DE MIRE



Fibre optique



Cran de mire standard

Pour changer le cran de mire, procédez comme indiqué dans la partie « CRANS DE MIRE DE RECHANGE ».



AUXILIAIRE D'ARMEMENT



1. Tirez la culasse vers l'arrière.



2. Retirez le cran de mire comme indiqué dans la partie « CRANS DE MIRE DE RECHANGE ».

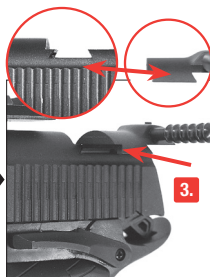

3. Placez l'unité auxiliaire d'armement dans le guidage en queue d'hirondelle.

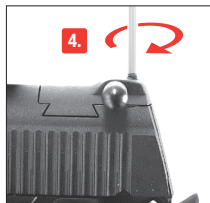

4. Fixez l'unité auxiliaire d'armement à l'aide d'une clé mâle à six pans de 1,5 mm.



5. Le levier d'armement peut être monté des deux côtés.



6. Poussez l'arrière de culasse vers le bas (désarmement de la culasse).

RAIL DE MONTAGE

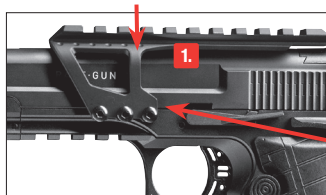

1. Placez le rail de montage.

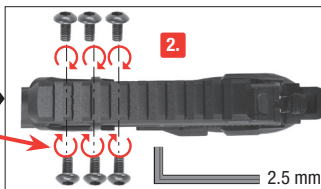

2. Fixez à l'aide de 6 vis.



HAUSSE

FR

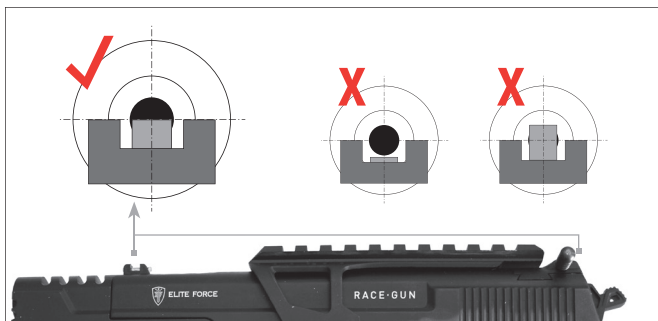

AJUSTAGE LA HAUSSE

Réglage en hauteur

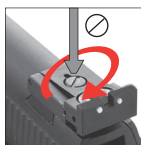

Tir trop haut   tourner vers la droite

Tir trop bas   tourner vers la gauche

Réglage latéral



Tir trop à gauche   tourner vers la droite

Tir trop à droite   tourner vers la gauche



TIR

FR



1. Enlevez la sûreté.



2. Pour charger l'arme, tirez le levier d'armement vers l'arrière jusqu'à la butée, puis ramenez-le vers l'avant.



3. Actionnez la détente.



NETTOYAGE DE CANON

FR



ATTENTION

- Déchargez l'arme avant de nettoyer l'arme.
- N'enfoncez pas la baguette de nettoyage violemment dans le canon, car elle pourrait l'endommager.
- Nettoyez les pièces métalliques extérieures à l'aide d'un chiffon doux préalablement imbibé d'huile pour armes.
- Ne versez jamais l'huile de silicone directement dans le canon.

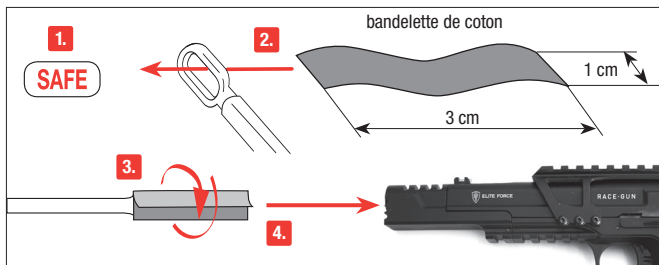

Mettez la sécurité de l'arme. Utilisez une tige fine d'une longueur d'env. 30 cm. Enroulez une bandelette de coton à son extrémité et nettoyez le canon avec une petite quantité d'huile de silicone.

ENTRETIEN (POUR LES ARMES AU CO₂ UNIQUEMENT)

Entretenez l'arme à intervalles réguliers (250 tirs) à l'aide d'une capsule d'entretien. Nous vous recommandons d'utiliser des capsules d'entretien Walther 4.1683.

Utilisation de la cartouche d'entretien :

Retirez les billes BB de l'arme, vissez la capsules d'entretien jusqu'à ce qu'elle soit bien en place et percée. Tenez l'arme à l'envers (poignée vers le haut et bouche pointée dans une direction sûre) et tirez jusqu'à ce que la capsules d'entretien soit vide.





MANEJO SEGURO DE ARMAS

ES

Deberá estar familiarizado con el manejo correcto y seguro de su arma. Con respecto a las reglas básicas para disparar con seguridad, considere cada contacto con el arma como parte de su manejo.

- Trate el arma como si siempre estuviera cargada.
- Cargue siempre el arma con el seguro activado para evitar disparos involuntarios.
- Mantenga el dedo siempre fuera del gatillo y colóquelo solamente cuando vaya a disparar.
- Utilice únicamente proyectiles específicos para esta arma.
- Mantenga la boca del arma siempre en una dirección segura.
- Sólo está permitido disparar el arma en la vivienda del propietario o en las zonas de tiro autorizadas por la policía, siempre y cuando el proyectil no pueda llegar más allá del área de tiro. Para ello, tenga presente siempre la distancia máxima de peligro del proyectil.
- Nunca transporte el arma cargada. Cárguela solamente cuando tenga intención de disparar.
- Nunca apunte con el arma hacia personas o animales. Evite los disparos en los que el proyectil pueda rebotar: nunca dispare sobre superficies lisas y duras, ni al agua.
- Antes de disparar, asegúrese que el blanco y el entorno sean seguros.
- Antes de transportar el arma o de recibirla de manos de otra persona compruebe siempre que está descargada.
- Asegúrese de que, aunque tropezara o cayera, todavía puede controlar la dirección a la que apunta la boca del arma.
- Por motivos de seguridad, cuando vaya a disparar póngase siempre gafas protectoras.
- Guarde el arma siempre descargada, separada de la munición y en lugar seguro para evitar que personas no autorizadas (personas sin formación, personas menores de 18 años, niños) puedan acceder a ella.
- Entregue esta arma, junto con las instrucciones de uso, únicamente a aquellas personas que:
 - estén perfectamente familiarizadas con el manejo de esta arma
 - hayan cumplido la edad mínima correspondiente fijada por la legislación en materia de armas del país respectivo.
- Cualquier modificación o reparación del arma deberá llevarla a cabo una empresa especializada o un armero.
- Nunca deje sin vigilancia un arma cargada.
- Siempre que entregue un arma a otra persona, asegúrese de que está descargada.

REPARACIONES

Una arma que no funcione perfectamente es peligrosa. Es difícil reparar uno mismo un arma, y un ensamblaje incorrecto puede producir anomalías de funcionamiento peligrosas.

Atención: La comprobación y reparación del arma sólo pueden llevarla a cabo especialistas autorizados o un armero.



INSTRUCCIONES DE SEGURIDAD | GARANTÍA

ES



ATENCIÓN

Por su propia seguridad y la de los demás, lea detenidamente las instrucciones de uso antes de disparar el arma por primera vez. Vendedores y compradores están obligados a cumplir con las normas de uso y posesión de armas de aire comprimido. Queda prohibida cualquier modificación de esta arma, ya que ello podría implicar un cambio en su clasificación legal. En caso de modificación quedaría extinguida de inmediato la garantía del fabricante.



AVISO

No porte o muestre este arma de aire comprimido en público. Puede ser motivo de confusiones e ilegal. Miembros de las fuerzas de seguridad y la policía pueden tomarla por un arma de fuego real. No modifique el color ni los elementos identificativos para hacer que se parezca más a un arma de fuego real. Es peligroso y puede ser un delito.

GARANTÍA

La empresa UMAREX se responsabiliza de reparar o sustituir su producto sin coste alguno en el plazo legalmente fijado a partir de la fecha de compra, siempre que el defecto no sea responsabilidad del propio usuario. Entregue el arma a un comerciante autorizado, describale el problema y adjunte el correspondiente comprobante de compra.

Las armas de aire comprimido de la empresa UMAREX GmbH & Co. KG se fabrican de conformidad con las normas de homologación del Instituto Federal PTB (Physikalisch-Technischer Bundesanstalt), con la Ley Federal alemana, la normativa que establece el centro CIP y la experiencia en fabricación de armas de UMAREX GmbH & Co. KG.

Por eso, no asumimos ninguna responsabilidad en el caso de que al exportar el arma a un país extranjero, ésta no cumpliera con la normativa legal local y el propietario o comprador tuviera que responder jurídicamente por dicho incumplimiento.

DATOS TÉCNICOS

Número de artículo	2.5799	2.6337-1
Sistema	CO ₂ Airsoft	
Propulsión	12 g CO ₂ Cápsula	
Kaliber / Munición	6 mm BB	
Capacidad	16 Tiros (BBs)	
Energía	2 J max.	
Velocidad	hasta 120 m/s	
Sistema de funcionamiento	Semi-Auto	
Color	negro	
Seguro	manual	
Longitud del cañón	160 mm	
Distancia máxima de peligro	250 m	
Peso	1100 g	
Longitud	265 mm	



DESIGNACION

ES



ALZA INTERCAMBIABLE

(premontada):

Fibra óptica



Alza estándar



PALANCA DE ARMADO:

Palanca de armado

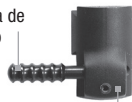

Unidad auxiliar de amartillado (premontado)



SEGURO

ES



ATENCIÓN

- Manipule la pistola sólo cuando esté asegurada.
- Asegúrese de que la boca apunte siempre en una dirección segura.

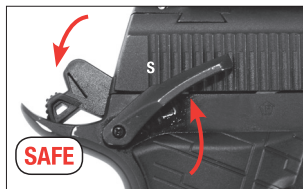
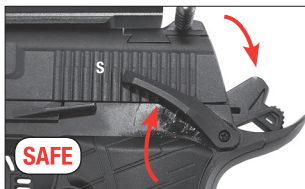

PROBLEMAS



PROBLEMAS

Potencia de disparo deficiente

El arma no dispara

Escasa velocidad de disparo

POSIBLES CAUSAS

	Seguro activado	Cartucho de CO ₂ sin perforar	Gas / Cartucho de CO ₂ vacío / cargador vacío	Cañón sucio	Temperaturas extremas	Munición errónea	Munición mal cargada	La mira no está bien ajustada
Potencia de disparo deficiente			●	●	●	●	●	●
El arma no dispara	●	●	●		●	●	●	
Escasa velocidad de disparo			●	●	●	●	●	



INSERCIÓN DEL CÁPSULA DE CO₂

ES

ATENCIÓN

- Utilice únicamente cápsulas CO₂ de 12 g.
- Para guardar el arma extraiga los cápsulas de CO₂.
- Al extraer el cápsula de CO₂, es posible que se escape una pequeña cantidad de gas. Procure que sus manos no entren en contacto con el CO₂ en caso de fuga, ya que un eventual contacto con la piel puede causar congelación. No exponga el cápsula de CO₂ a un calor excesivo ni lo guarde a temperaturas superiores a los 54°C. Observe siempre las advertencias e instrucciones de seguridad del fabricante sobre la manipulación y el almacenamiento del cápsula de aire comprimido.



1. Presione el retén del cargador. **2.** Extraiga el cargador.



3. Ejerza presión sobre el tornillo para que gire el tapón roscado. **4.** Gire hacia abajo el tornillo de pinchado del cartucho.

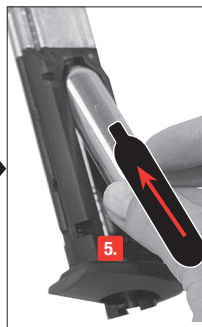

5. Inserte el cartucho de CO₂ tal y como muestra la imagen.



6. Gire hacia arriba el tornillo de pinchado y pinche el cartucho.



7. Introduzca el cargador.



CHARGER DEL CARGADOR

ES

ATENCIÓN



Utilice únicamente bolas BB (que no presenten defectos) de calibre 6 mm. No utilice en ningún caso los siguientes tipos de bolas BB:

1 Diámetro superior a los 6 mm, 2 Con cortes, 3 Con mitades que no coinciden, 4 Usadas o sucias. Si se utilizan proyectiles distintos de los apropiados, quedará anulada la garantía. Se recomienda el uso de bolas de precisión de la marca UMAREX/Walther. Para garantizar el buen funcionamiento del magazín, evite que la suciedad o el polvo entren en el mismo.



1. Presione el retén del cargador. 2. Extraiga el cargador.

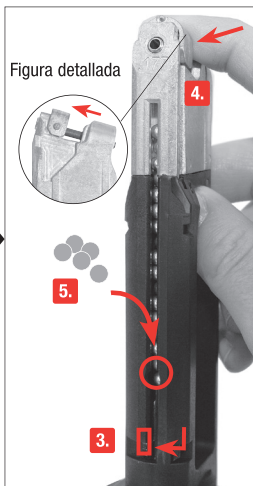

3. Desbloquee el elevador. 4. Durante la carga, desplace y sujete el elevador conforme lo muestra la figura detallada. 5. Cargar los BBs. Desbloquee el elevador.

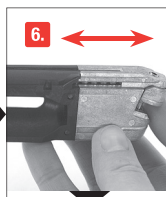

6. Sostenga el cargador en posición horizontal para que los balines lleguen al elevador. 7. Introduzca el cargador.



ALZA INTERCAMBIABLE

ES

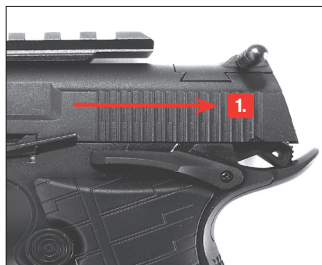

1. Tire de la corredera hacia atrás.

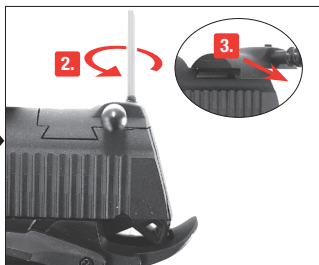

2. Suelte la unidad auxiliar de amartillado con una llave Allen de 1,5 mm **3.** Tire de la corredera hacia atrás, extráigala de la guía.



4. Desenrosque un poco el espárrago roscado para colocar el alza en la guía de milano.

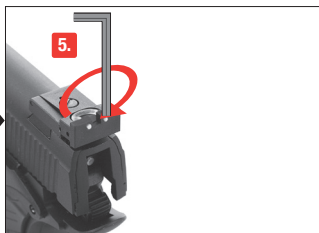

5. Apriete bien el tornillo. Presione hacia abajo la palanca de bloqueo de la corredera (desarmar la corredera).



MODIFICACIÓN DEL ALZA

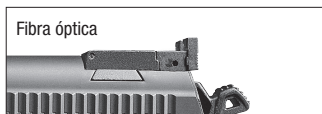

Fibra óptica

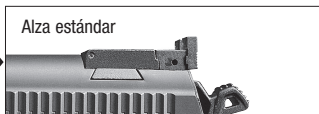

Alza estándar

La modificación del alza se realiza en el orden inverso, como se describe en "ALZA INTERCAMBIABLE".



SOPORTE DE AMARTILLADO



1. Tire de la corredera hacia atrás.



2. Extraiga el alza como se describe en "ALZA INTERCAMBIABLE".

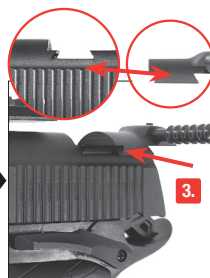

3. Coloque la unidad auxiliar de amartillado en la guía de cola de milano.

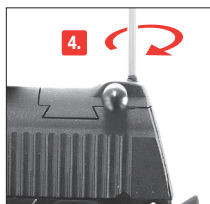

4. Fije la unidad auxiliar de amartillado con una llave Allen de 1,5 mm.



5. La palanca de armado se puede montar en los dos lados.



6. Presione hacia abajo la palanca de bloqueo de la corredera (desarmar la corredera).

RIEL DE MONTAJE

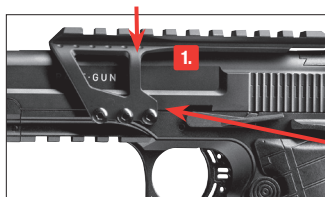

1. Coloque riel de montaje.

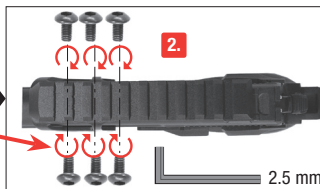

2. Fije los 6 tornillos.



MIRA

ES

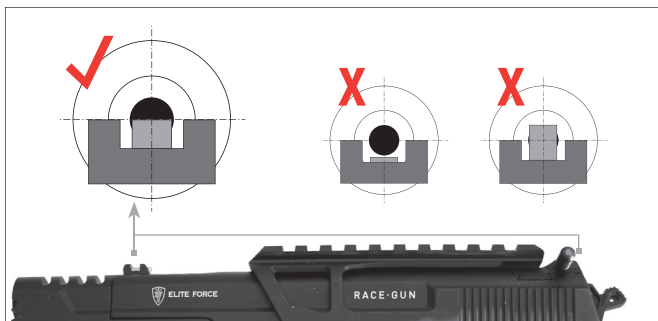

AJUSTE DE MIRA

Ajuste en altura

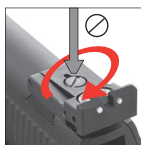

Disparo muy alto



gire hacia la derecha

Disparo muy bajo



gire hacia a la izquierda

Ajuste lateral



Disparo desviado hacia la izquierda



gire hacia la derecha

Disparo desviado hacia la derecha



gire hacia a la izquierda



DISPARO

ES



1. Quite el seguro.



2. Para cargar el arma, tire de la palanca de armado hacia atrás hasta el tope y, a continuación, desplácela hacia adelante.



3. Accione el gatillo.



LA LIMPIEZA DE CAÑÓN

ES



ATENCIÓN

- Descargue el arma antes de limpiar el arma.
- No debe forzar la varilla de limpieza para introducirla dentro del cañón, porque podría dañar el arma.
- Limpie las piezas metálicas exteriores con un trapo suave, humedecido con aceite para armas.
- No vierta nunca aceite de silicona directamente dentro del cañón.

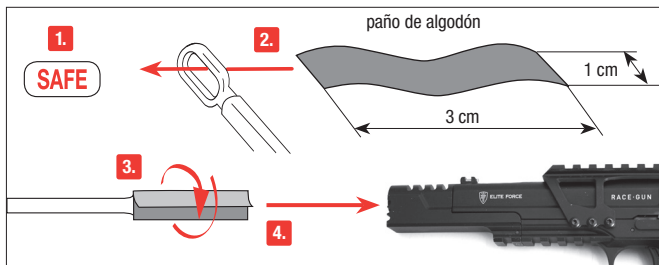

Asegure el arma. Coja una barra estrecha y larga de unos 30 cm. Enrolle un paño de algodón por el extremo, humedézcalo con un poco de aceite para armas y limpie el cañón con ayuda del mismo.

LIMPIEZA SOLAMENTE PARA ARMAS DE CO₂.

Limpie periódicamente el arma (cada 250 disparos) utilizando un Cápsula de mantenimiento. Recomendamos la utilización de cápsulas de mantenimiento WALTHER 4.1683.

Uso de la cápsula de mantenimiento:

Extraiga los BBs del arma, introduzca la cápsula de mantenimiento y pínchela. Apunte el arma hacia abajo (el arma debe estar cabeza abajo o invertida) y dispare hasta vaciar el cargador.



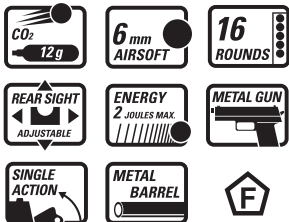

UMAREX®

UMAREX GmbH & Co. KG

Donnerfeld 2

59757 Arnsberg | Germany

Phone: +49 29 32 / 638-01

Fax: +49 29 32 / 638-222

verkauf@umarex.de | sales@umarex.de

www.umarex.com

We reserve the right to make color and design changes and technical improvements. No responsibility is accepted for printing errors or incorrect information.

Änderungen in Farbe und Design, sowie technische Verbesserungen, Druckfehler und Irrtum vorbehalten. Alle Angaben ohne Gewähr.

Sauf modifications de la couleur et du design ainsi que des améliorations techniques, erreurs d'impression et erreur. Toutes les données sont fournies sans garantie.

Salvo modificaciones de color y de diseño así como mejoramientos técnicos, erratas y error. Todos los datos sin garantía.

© UMAREX GmbH & Co. KG